

Fluid-Damped Single-Point Load Cell

FEATURES

- Capacities 2–50 kg
- Painted steel construction
- OIML R60 and NTEP approved
- IP66 protection
- Available with metric and UNC threads
- Optional
 - Stainless steel construction



APPLICATIONS

- Multi-head filling machines
- Check weighing
- Grading machines
- Liquid filling
- Dynamic weighing

The Model 240 brings load cell adaptability into check weighing and grading applications.

Approved to OIML R60 and NTEP standards, sealed to IP66 level and available in coated steel or stainless steel, the Model 240 is suitable for most wash-down applications.

DESCRIPTION

Model 240 is specifically designed to be used where fast acquisition of a stable load signal is paramount. The Model 240's unique fluid damping system allows the load cell to be used in applications that previously required the use of LVDT's or similar types of measuring devices.

The two additional sense wires feed back the voltage reaching the load cell. Complete compensation of changes in lead resistance due to temperature change and/or cable extension, is achieved by feeding this voltage into the appropriate electronics.

OUTLINE DIMENSIONS in millimeters

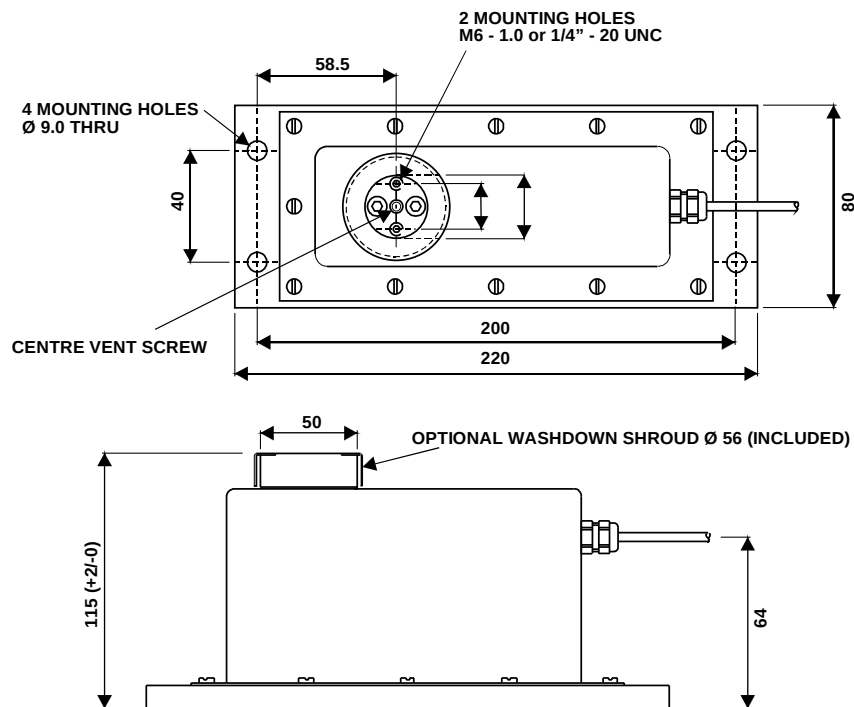

Fluid-Damped Single-Point Load Cell

SPECIFICATIONS				
PARAMETER	VALUE			UNIT
Rated capacity—R.C. (E max)	2, 3, 5, 7, 10, 15, 20, 30, 50**			kg
OIML accuracy class	NTEP	Non-Approved	C3*	
Maximum no. of intervals (n)	5000	1000	3000	
Y = E _{max} /V _{min}	12000	1750	9000	Maximum available
Rated output—R.O.	2.0			mV/V
Rated output tolerance	0.2			±mV/V
Zero balance	0.1			±mV/V
Zero return, 30 min.	0.033	0.050	0.015	±% of applied load
Total error	0.050	0.025	0.015	±% of rated output
Temperature effect on zero	0.0026	NA	0.0026	±% of rated output/°C
Temperature effect on output	0.0010	NA	0.0010	±% of rated output/°C
Temperature range, compensated	-10 to +40			°C
Temperature range, safe	-30 to +70			°C
Maximum safe central overload	150			% of R.C.
Ultimate central overload	300			% of R.C.
Excitation, recommended	10			VDC or VAC RMS
Excitation, maximum	15			VDC or VAC RMS
Input impedance	415±15			Ω
Output impedance	350±3			Ω
Insulation resistance	>1000			MΩ
Cable length	To suit			m
Cable type	6-wire, braided, polyurethane, silicone gel impregnation			Standard
Construction	Painted mild steel***			
Environmental protection	IP66			

* 50% utilization
 ** 2 and 3 kg are not approved by NTEP or OIML
 *** Stainless steel available
 All specifications subject to change without notice.

WIRING SCHEMATIC DIAGRAM

