

Stainless Steel Shear Beam Load Cell

FEATURES

- Capacities 300–5000 kg, 1000–5000 lbs
- Stainless steel construction
- OIML R60 and NTEP approved
- Hermetically sealed to IP68 ~~IP69K~~
- Specially designed for harsh environment
- Optional
 - Ex ia IIC T6 hazardous area approval
 - FM approval available
 - 1100Ω impedance available



APPLICATIONS

- Low profile platforms
- Pallet truck weighing
- Tank and silo weighing
- Harsh environment weighing
- Food industry weighing

profile platforms, pallet truck weighers, tanks and silos. The guide slots incorporated into the upper and lower mounting faces enable manufacturers to easily position the load cell.

Hermetically sealed against moisture, the construction of the Model 3510 in combination with a polyurethane dual shielded cable, enables continuous operation in harsh environments while maintaining a high operating specification.

DESCRIPTION

Model 3510 provides the weighing industry with the ultimate protection necessary for today's hostile environments in an economical low profile range suitable for platform scale manufacture.

Its low profile and all welded sealing combined with high accuracy makes this load cell ideally suited for low

voltage into the appropriate electronics. The two additional sense wires feed back the voltage reaching the load cell. Complete compensation of changes in lead resistance due to temperature change and/or cable extension, is achieved by feeding this

OUTLINE DIMENSIONS in millimeters

**DIMENSIONS FOR CAPACITIES
300, 500, 1000 and 2000 kg**

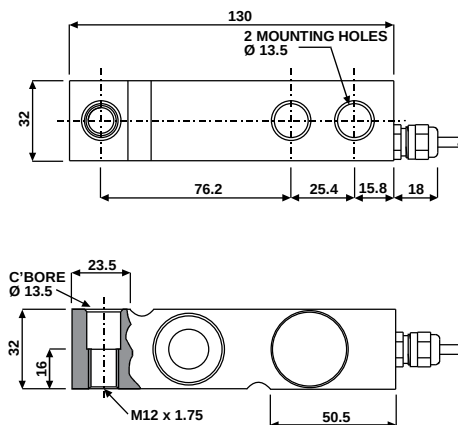

**DIMENSIONS FOR CAPACITIES
3000 and 5000 kg**

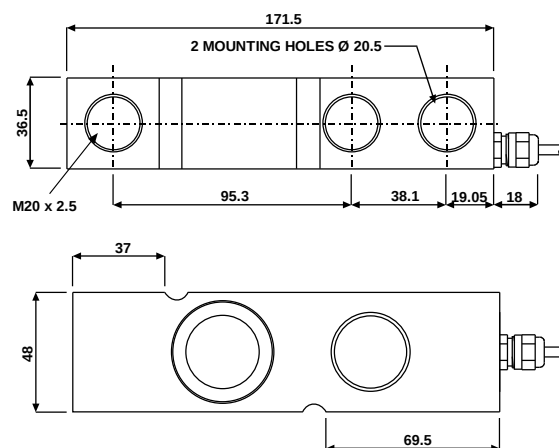

Standard end loading shown.

Options include:

'Through-hole' - plain or threaded.

'T-End' - supplied current and voltage matched for platforms.

Imperial capacities can be manufactured with M12 or 1/2"-20 UNC threading

Stainless Steel Shear Beam Load Cell

SPECIFICATIONS					
PARAMETER	VALUE				UNIT
Rated capacity—R.C. (F_{max})	300, 500, 750, 1000, 1200, 2000, 3000, 5000				kg
Rated capacity—R.C. (F_{max})	1000, 1500, 2500, 4000				lbs
NTEP/OIML accuracy class	NTEP	Non-Approved	C3	C6	
Maximum no. of intervals (n)	3000 single 5000 multiple	1000	3000 ⁽¹⁾	6000 ⁽²⁾	
$Y = F_{max}/V_{min}$	12500	1400	12000	20000	Maximum available 20000
Rated output—R.O	2.0 for kg and 3.0 for lbs				mV/V
Rated output tolerance	0.1				±% of rated output
Zero balance	2				±% of rated output
Zero return, 30 min.	0.015% for III/3000 Single 0.010% for III/5000 Multiple	0.0300	0.0170	0.0083	±% of applied load
Total error	0.0200	0.0500	0.0200	0.0100	±% of rated output
Temperature effect on zero	0.0023	0.0100	0.0023	0.0007	±% of rated output/°C
Temperature effect on output	0.0010	0.0030	0.0010	0.00058	±% of applied load/°C
Temperature range, compensated	-10 to +40				°C
Temperature range, safe	-30 to +80				°C
Maximum safe central overload	150				% of R.C.
Ultimate central overload	300				% of R.C.
Excitation, recommended	10				VDC or VAC RMS
Excitation, maximum	15				VDC or VAC RMS
Input impedance	380±10				Ω
Output impedance	355±5				Ω
Insulation resistance	>2000				MΩ
Cable length	5				m
Cable type	6-wire, braided, polyurethane, dual floating screen				Standard
Construction	Stainless steel				
Environmental protection	IP68, IP69K				
Recommended torque	136.0 (3000 and 5000 kg—205.0)				N*m

⁽¹⁾ 50 % utilization

⁽²⁾ Capacities 300-1200 kg, and 1000-2500 lbs only

All specifications subject to change without notice.

WIRING SCHEMATIC DIAGRAM

